

MADE IN USA



OWNER'S MANUAL



Sun Dolphin Models:

Pro 120

Pro 102

Pro 94



1790 Sun Dolphin Drive
Muskegon, Michigan 49444

phone 231-733-2725

fax 231-739-4502

email klsales@klindustries.com

website www.klindustries.com

Big Bass Boat Features in a Compact Package

Congratulations on the recent purchase of your new fishing boat! You have purchased a boat from one of the nation's leading manufacturers of small boats. Your boat represents years of commitment to product design, excellence in engineering and quality in manufacturing. With proper care and maintenance your boat should last for many years to come. Please call our helpful and knowledgeable Customer Support Department if you have any questions or concerns.

IMPORTANT

This manual has been compiled to help you operate your boat with safety and pleasure. It contains details of the boat, the equipment (supplied or fitted), its systems and information on its operation and maintenance. Please read it carefully and familiarize yourself with the boat before using.

If this is your first boat or you are changing to a small boat you are not familiar with, for your own comfort and safety, please ensure that you obtain handling and operating experience before "assuming command" of the boat. Your local dealer will be pleased to advise you of its operation or direct you to local schools or competent instructors.

ABOUT YOUR FISHING BOAT

Deck and Hull

Your fishing boat is manufactured from High Density Polyethylene (HDPE). It is a very durable material. Our specially formulated HDPE has an ultra-violet inhibitor blended throughout the material to reduce color fade and maintain its strength. Polyethylene is a somewhat flexible material with some memory. This means it has a tendency to return to its original molded shape if distorted.

Capacity and Flotation

The capacity of your boat, in both passengers and added cargo, is determined by the boat's size and flotation. Each boat has a capacity tag clearly displayed on the craft. Flotation is provided by closed cell foam located between the deck and hull. The foam is strategically placed to provide flotation under normal loading conditions. All Sun Dolphin Pro models meet U.S. Coast Guard safety standards and are CE certified.

PAPERWORK

Warranty Registration

To properly register your boat with KL Industries for warranty validation please fill out the warranty registration form online at www.klindustries.com. Please review our full warranty statement. If you are unable to register your boat online please contact our Customer Support Department at 231-733-2725. The serial number can be found on the outside of the hull in the back right corner just under the rubrail. See Photo #1.

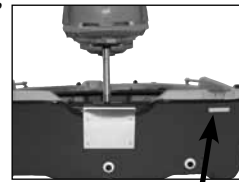

Photo #1 Serial Number
Location
Pro 120 shown

Manufacturer's Statement of Origin (MSO)

Each boat comes with a document called a Manufacturer's Statement of Origin (MSO). Think of it like the title to your car. It's your proof, along with your sales receipt, of ownership. You'll need both the MSO completed and signed by the retailer and your sales receipt to register the boat with your state licensing bureau.

Most states require that you register your boat if it has a motor or will be used with a motor. Also, several states require you to register the boat if it exceeds a certain length. To determine the registration requirements please check with your state licensing bureau. This varies from state to state but is often the Secretary of State, Department of Natural Resources or the Department of Motor Vehicles.

Owner's Manual

Keep your owner's manual for future reference. It is a good idea to write down the following information:

Serial Number

Date of Purchase

Purchased from

SETTING UP YOUR FISHING BOAT

Components and Basic Set-Up

Please follow the recommended steps to prepare your boat. Note: the manual will refer to different models. The large decal on the side of the boat shows the model.

Parts

- The Pro 120 comes with: (2) padded seats, (2) kingpin swivels, (2) pedestals, (3) transom drain plugs installed, (1) drain plug installed in front/center cooler, (1) stern light (located under the rear casting deck) and (1) trolling motor plug.
- The Pro 102 comes with: (2) padded seats, (2) kingpin swivels, (3) drain plugs installed, (1) stern light, (1) bow light, (1) battery box, (1) accessory kit and (1) trolling motor plug.
- The Pro 94 comes with: (2) seats, (2) kingpin swivels, (3) drain plugs installed, (1) battery strap and (1) trolling motor plug.

Applying Decals

Before applying boat registration decals, clean the area with alcohol or any solvent that does not leave a residue. Make sure solvent is put aside and is dry. Using a propane torch, lightly pass the flame back and forth over the area where the decals will be applied. **Do not try to heat the surface.** This process will enhance the adhesion of the decals.

Installing the Seats

Follow seat installation instructions provided with seats.

Installing Drain Plugs

Just like any boat, your boat may take on some water. Because of its flexible nature, a polyethylene boat is prone to accumulate a small amount of water between the deck and hull. Water may accumulate between the deck and hull due to rain, waves and condensation. This is normal, not a defect, and should be drained after use. Remove the plug and lift the bow of the boat (lift the stern on the Pro 94) so all the water drains to the transom. Please be sure to secure the drain plug after draining.

The Pro 120 has three drain plugs located on the transom. One drains the water from the livewell, another drain eliminates any water which condenses or seeps between the deck and hull. The third plug drains the water that gets onto the deck. The built-in cooler in the bow has a drain which empties between the deck and hull. See Photo #2.

The Pro 102 has three drain plugs. Two are located on the transom. One drains the water that gets onto the deck. The other eliminates any water which condenses or seeps between the deck and hull. The third is located in the livewell.

The Pro 94 has three drain plugs. One drains the water that gets onto the deck and is located on the transom. Another drain eliminates any water which condenses or seeps between the deck and hull and is located on the bow just above the bow eye. The third is located in the livewell.

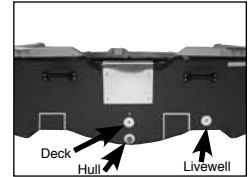

Photo #2 Drain Plug Locations
Pro 120 shown



Photo #3 Control Panel
Pro 120 shown

Electrical Power

Use a 12V Deep Cycle Marine Battery (not included) available from marine dealers, outdoor retailers and mass merchandisers. To install, place the battery in the battery compartment or case depending on the model. Make sure the battery is secured using the holding strap so it can't bounce or slide inside the compartment. The weight and sharp corners of the battery could crack the compartment liner. Connect the wires as follows:

RED to POSITIVE (+) terminal

BLACK to NEGATIVE (-) terminal

Installing Oar Locks (if desired)

Note: not all models include an Oarlock Kit. If you would like an Oarlock Kit, it is available for purchase. To install follow the instructions included with the Oarlock Kit. Note: that if the installation instructions are not followed, the oarlocks may come loose and the boat may be damaged.

You will also need oars, which are available from KL Industries. Please call our Customer Support Department or order online www.klindustries.com.

Mounting a Small Outboard Motor

If you wish to use an outboard motor, attach it to the transom following the instructions provided with the motor. **Do not mount a motor with a horsepower rating higher than the rating on the boat capacity plate.** A standard short shaft is recommended.

The Pro 120 is designed with a planing hull. However, it likely will not plane with less than a 9.9 HP motor. Two-cycle outboards generally provide better performance on a small boat because they are lighter in weight than four-cycle motors.

Installing a Trolling Motor

The Pro 120 model has a bow socket to connect a trolling motor. A foot controlled trolling motor may also be used with this model. A deck motor mount is available for purchase. Please contact our Customer Support Department or order online at www.klindustries.com. Maximum thrust: 55 lbs. Shaft length: standard. Note: the Pro 120 has a feed tube from the front compartment to the battery compartment in the back of the boat to internally feed the wires from bow to stern for direct hook up to the battery.

The Pro 102 model has sockets to connect a trolling motor to either the bow or transom of the boat. Maximum thrust: 40 lbs. Shaft length: standard.

The Pro 94 model has a transom socket to connect a trolling motor. Maximum thrust: 40 lbs. Shaft length: standard.

Many trolling motors come with “alligator clips” or “ring connectors” for direct connection to a battery. To plug the trolling motor into the socket, you may need to replace the clips or connectors with a male plug (included with accessory packet). To do this:

1. Cut the trolling motor power wires just behind the alligator clips or ring connectors and strip about ½” of the insulation from the end of these wires.
2. Connect the trolling motor power wires to the plug wires using the connectors included in the accessory packet or by soldering.

Note: Be sure to connect the same color wires together: the RED wire on the plug is positive (+) the BLACK wire is negative (-). Consult the trolling motor instructions for more details.

ELECTRICAL SYSTEMS OVERVIEW

Navigation Lights

If you operate the boat after dusk or before dawn you must have navigation lighting that meets US Coast Guard standards. If you are anchored or not moving only the stern light (sometimes called an all around light) should be on. If the boat is moving or underway both the bow lights and stern light must be on.

The Pro 120 is equipped with built-in bow lights (red/green). The stern light is operated by installing the light pole into the socket. The lights can be operated by the control panel on the rear, starboard side of the boat.

The Pro 102 navigation lighting is operated by installing the light poles into the sockets. The bow lights (red & green) are installed into the front socket and the stern light is installed into the rear socket.

On models with bow and stern trolling motor plugs, be sure to connect both circuits to the battery. There will be two red and two black wires. Connect both red wires to + (positive) battery terminal. Connect both black wires to - (negative) battery terminal.

The Pro 94 is not equipped with navigation lighting.

Livewell Aerator Pump

If your boat has an aerator pump, it is controlled by a switch on the control panel located on the starboard side of the boat for the Pro 120 and the on/off switch for the Pro 102.

Circuit Breakers

The Pro 120 uses a 5 amp. circuit breaker is used for the lights and aerator and a 50 amp. circuit breaker is used for the front trolling motor connection. If any of your electrical systems are not working, try resetting the circuit breaker by pushing the breaker button found on the control panel.

The Pro 102 uses 50 amp. in-line fuses. If any of your electrical systems are not working, check the in-line fuses located next to the battery terminals in the wire. Replace if necessary.

INSTALLING ACCESSORIES

Fish Finders/Depth Finders Pro 94 and Pro 102 Models

1. Hook up power for the fish finder or other accessories. The power will need to be connected directly to the battery. **Since this is not a fused connection, please see the installation instructions included with the fish finder.**
2. Place the main unit of the fish finder or other accessory on the deck in any location that is convenient.
3. The transducer for the fish finder can be mounted to the trolling motor using stainless steel hose clamps. The transducer can also be mounted on a raised mounting block located on the port (left) side of the transom for the Pro 102 and Pro 94. This raised mounting block has a small piece of durawood behind it as a backer. **Do not mount the transducer anywhere else on the transom. There are no other wood backers (except for the center section where the motor is mounted). Mounting onto the plastic itself will not provide adequate support, and will create a leak in the hull.**

Fish Finders/Depth Finders Pro 120

The transducer for the fish finder may be mounted on either side of the stern. See photo #6. Use caulking to seal the mounting screws and locate the transducer away from the turbulence. The transom consists of 1" plywood. The transducer can be placed on either side per the diagram. Do not mount into the outside sponson because there is only the material thickness of the hull to screw to and a leak will result.



Photo #6 Mounting
Locations
Pro 120 shown

See the instructions from the fish finder manufacturer for more details.

PRE-LAUNCH CHECK

- Check the weather and wave conditions.
- Review the maximum capacities on the capacity plate, located on the rear starboard side of the deck. Ensure you are safely within these limits.
- Make sure your drain plugs are installed and secure.
- Some water accumulation should be expected between the deck and hull. It is not necessarily an indication of a serious leak in the hull. Water can seep through and around some fasteners during heavy rain or will accumulate just from normal condensation. Drain the space between the deck and hull of any accumulated water by following the boat specific "Installing Drain Plugs" instructions. Reinstall the drain plug.
- Make sure all passengers are wearing Personal Flotation Devices (life jackets).
- When the boat is under power, it is advised that the operator and any passengers remove the seat pedestal (Pro 120 only) and place the seat directly into the seat base. **Do not sit elevated in the pedestal seats while the boat is in motion.**

- Check and tighten if necessary all motor mounting clamps.
- When loading, distribute the weight of fuel tank, battery, tackle boxes etc. evenly across the boat so that it will sit reasonably level in the water. Remember this is a small boat and extra caution should be taken to prevent overloading the craft as this could result in unsafe operating characteristics.

OPERATING THE BOAT

Launching Tips

- When launching the boat from shore it is better to enlist the help of a bystander or passenger to help lift the boat and carry it to the water. You can drag the boat but carrying it will prevent excessive hull abrasion over time.
- Be sure motor is tilted up to prevent damage when lowering the boat into the water.
- If launching from a trailer, make sure to remove all tie downs before backing onto the launching ramp.
- Make sure to install all drain plugs before putting the boat in the water.
- When entering the boat, step in the center of the boat so the boat remains stable. Do not step on the gunwale (top edge of the side of the boat), which could cause the boat to tip.
- After the boat is in the water, but before leaving from shore, check to make sure the boat sits reasonably level fore to aft and side to side. If not, redistribute the items you have on board.
- Be especially conscious of the shore condition. Sharp rocks, sharp edges on break walls, concrete aprons, etc. can seriously chafe the hull if you drag or slide the boat over these surfaces.

Mooring and Docking

- Avoid mooring or docking in very shallow water where the hull will hit bottom.
- Use boat fenders or other cushioning to prevent wave action from scraping the hull against the dock.

Livewell Operation

- Fill the livewell about 2/3 full of water. **Do not overfill. The excess water will seep between the hull and deck.** Try to use cool water. Cooler water reduces the fish's need for oxygen. Keep the lid closed when possible to help keep the water cool.
- The Pro 102 and Pro 120 models have a recirculating aerator pump. It's not necessary to run the pump continuously to keep fish alive. Running it for five minutes or so every ½ hour is adequate if the water is cool, longer if the water is warm. Sometimes the pump intake vanes and spray head parts can become clogged with debris. Periodically check them and clean when necessary. The pump draws approximately 1 ½ amp @ 12 VDC. The switch is on the electrical control panel.
- Drain the livewell by removing the drain plug.

Navigation Lights (available on Pro 102 and Pro 120 models)

The lights should always be used if there are poor lighting conditions, e.g. dusk, dawn, fog etc. If you are anchored or not moving only the stern light (sometimes called an all around light) should be on. If the boat is moving or underway both the bow lights and stern light must be on. See Electrical Systems Overview for light installation instructions.

Traveling Across the Water

Do not be concerned if you notice a slight hull flexing during use. The boat is designed to flex and absorb minor bumps without damage. This flexing is one of the great advantages of polyethylene.

Trim /Planing (all models)

The Pro 120 is designed with a planing hull. However it likely will not plane with less than a 9.9 HP motor. Two-cycle outboards generally provide better performance on a small boat because they are lighter in weight than four-cycle motors.

The Pro 94 and Pro 102 models are not designed to plane. However, they will travel smoothly if loaded and trimmed properly.

With most outboard motors, you can adjust the trim. This is the angle between the power unit of the motor (prop) and the transom of the boat. If the motor is angled out too far, the bow will rise sharply when power is applied. When the prop is angled too close to the transom, it will tend to push the bow down when power is applied.

Adjusting the weight distribution in the boat will also help the boat travel smoothly. If the bow lifts too much, shift more of the weight forward. If the bow tends to plow down in the water, shift weight toward the stern.

TRANSPORTING

Transporting by Pickup Truck

All models can be conveniently transported in the back of a full size pickup truck. Be sure to tie the boat down snugly using several tie down straps. **Do not over tighten the straps. This will distort the deck and hull.**

Trailer

If your boat will be transported on a trailer here are some important considerations. See Photos #4 & #5.

- Ensure that the trailer has supporting bunks that are 5' to 8' long. They should be made from 2" x 4" or 2" x 6" stock turned wide side up. If the trailer doesn't have bunk supports this size, you'll need to make them. Transporting and especially storing a boat on a trailer with too short or too narrow supports will cause the hull to dent and will

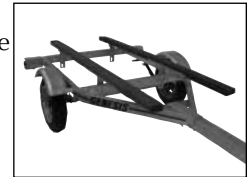

Photo #4 Correct



Photo #5 Incorrect

significantly reduce performance.

- Do not wind the winch too tight. Just enough to snug it against the winch stop is adequate. Over tightening may distort the bow over time.
- Loosen the transom or gunwale tie down straps if the boat will be left on the trailer for more than 1-2 days. If the straps are left tight the boat may distort under pressure.

CARE AND MAINTENANCE

- With minimal care and maintenance, your boat has been designed to provide you with many years of enjoyment.
- HDPE is very impact resistant but it is vulnerable to excess abrasion. Avoid dragging the boat across gravel, asphalt or concrete. If you wear a hole in the boat below the waterline HDPE is very difficult to repair. Nothing sticks to HDPE other than molten HDPE. Most adhesives even those that are very aggressive will only make a temporary bond and probably will not be waterproof.
- Drain any water accumulated between your deck and hull.
- Your boat can be cleaned with warm water and any standard detergents. More difficult stains, such as brackish watermarks, may be cleaned with a petroleum based cleaner. Read the manufacturers instructions carefully before using any cleaner. Do not use Armour-All® or other plastic conditioner products. They can discolor and even weaken the plastic. Do not use abrasive cleaning products.
- If your boat will be used in salt-water environments, it is suggested that the boat and components be rinsed thoroughly with fresh water after each use. Barnacles and other marine life will form on the hull surface if the boat is left in salt or brackish water for extended periods of time. Carefully scrape off the hull surface periodically with a putty knife or stiff brush. They'll be easier to remove if you keep the surface wet. Painting the hull with antifouling bottom preservative will help minimize barnacle and algae buildup.
- Periodically check and clean the battery terminals and wire leads.
- Remove corrosion from trolling motor harness connections.
- Spray electrical connectors with a lubricant such as Super Lube or CRC 56.
- Periodically check the operation of the aerator and lights.
- Periodically inspect all bolts and screws to ensure proper performance and safety.
- The carpet on the Pro 120 model is manufactured from 100% UV stabilized weather resistant polypropylene and can be cleaned with any standard carpet cleaner.
- Polyethylene is a somewhat flexible material with some memory. This means it has a tendency to return to its' original molded shape if distorted. If this occurs follow these steps:
 1. Relieve the pressure that caused the dent or distortion by supporting the boat differently or removing gear or the motor etc.
 2. Place the boat in the warm sun. Usually the south side of a building is the warmest spot. As the boat warms up usually (but not always) the boat will return to its original molded shape. This may take a few hours or a couple of weeks depending upon outside temperatures and the degree of distortion.

STORAGE

- Remove the boat from the water. Leaving the boat in the water for any longer than a few days will promote algae growth on the hull.
- Winter can be very hard on boats. We advise cleaning and coating electrical fittings with CRC 56 or battery terminal protectant prior to storage. For best results we suggest a mooring cover, which prevents water and debris from accumulating. Custom fit boat covers are available from KL Industries. Please call our Customer Support Department or order online at www.klindustries.com. If possible store your boat in a garage or barn.
- Make sure all water is drained from between the deck and hull.
- When storing your boat, open the drain plug and tilt the bow up for the Pro 102 and Pro 120 models to ensure proper drainage. Tilt the Pro 94 stern up because the drain is in the bow of the boat.
- Don't allow water to accumulate between the deck and hull and freeze. Freezing damages the flotation foam.
- Close the cap on the bow and/or stern light sockets on the Pro 102 and Pro 120 models.
- Remove all seats, fuel tanks, batteries and other accessories.
- Don't fill the boat with gear.
- Release the tension from winch and tie down straps.
- Don't store the boat on sawhorses.

Please Choose Your Model

Pro 120

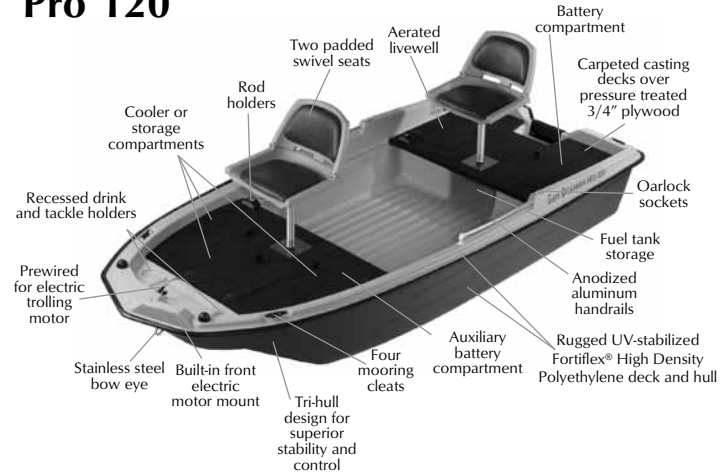

Also Features:

- Meets CE and US Coast Guard Safety Standards
- Polyurethane foam injected floor with aluminum stringers for rigidity
- Closed cell polystyrene foam flotation
- Fused control panel
- Navigation lights

Specifications

Length	11'3"	343cm
Width	62"	157cm
Height	24"	61cm
Weight	238 lbs.	108kg
Capacity	649 lbs.	294kg
HP Rating	15*	

* Not recommended for 4-cycle motors over 8 hp

Please Choose Your Model

Pro 94

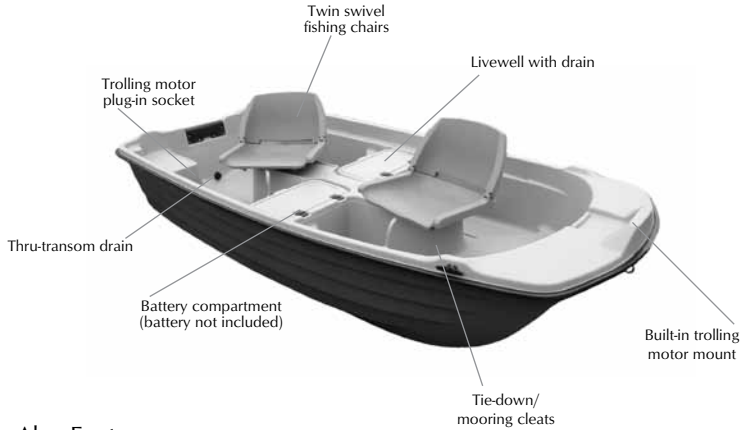

Also Features:

- Meets CE and US Coast Guard Safety Standards
- Made of durable, dent-resistant High Density Polyethylene
- Fits in the back of a pick-up, no trailer needed
- Pre-wired for trolling motor
- Livewell with drain
- Two-year hull and deck warranty

Specifications

Length	9'4"	284cm
Width	55"	140cm
Height	23.25"	59cm
Weight	150 lbs.	68kg
Capacity	439 lbs.	199kg
HP Rating	5	

Pro 102

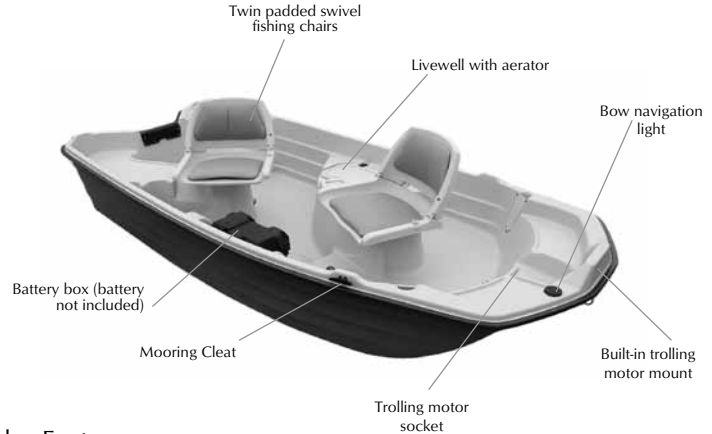

Also Features:

- Meets CE and US Coast Guard Safety Standards
- Fits in the back of a pick-up, no trailer needed
- Pre-wired for trolling motor at bow and stern
- Livewell with aerator pump
- Two-year hull and deck warranty

Specifications

Length	10'2"	310cm
Width	56"	142cm
Height	23"	58cm
Weight	165 lbs.	75kg
Capacity	469 lbs.	213kg
HP Rating	7	

PARTS LIST

***Please have serial number available when ordering**

PRO 120

12572	Battery Strap w/holder
12021	Rivet for Battery Strap (need 4)
11382	Carpet Green per Yard
11348	Cast Deck Green Front Kit (Kit includes screws)
11349	Cast Deck Green Rear Kit (Kit includes screws)
12537	Hinge
0127	Screws for Hinge (need 6)
0017	Circuit Breaker 50 Amp
12527	Control Panel
12052	Screw for Control Panel (need 4)
12801	Decal Pro 120 Dk Green
12503	Drain Plug Thru Hull
12504	Gasket for Drain Plug (need 1)
12513	Thru Hull Fitting (livewell)
12513-PS	Thru Hull Fitting (deck drain) (includes drain plug and drain plug gasket)
12513-P	Thru Hull Fitting (between deck and hull)
12441	Gasket for Through Hull (need 2)
12233	Hand Rail
12561	Bow Light (set of 2)
0129	Screw for Bow Lights (need 3 per light)
0040	Light Post Clip
12033	Screw for Clip (need 1)
12571	Light Socket
12042	Screw for Light Socket (need 4)
12574	Light Stern
12700	Rod Holder
12033	Screw for Rod Holder (need 2)

11774	Rub Rail Assembly 27'
12006	Rivet (need 14)
12036	Rivet Burr for Rivet (need 14)
12247	Motor Mount Plate Rear
12045	Screw for Rear Motor Mount (need 6)
12588	Oarlock Socket (pair)
12415	Plate for Oarlock
12065	Screw for Oarlock Socket (need 2)
12084	Nylock for Screw (need 2 per socket)
12583	Seat Base For Post (on boat)
12091	Screw for Seat Base (need 6)
0098	Nylock for Screw (need 6)
4464	Washer for Screw (need 6)
12007	Washer (need 4 per seat)
12336	Seat Green Padded
12582	Post 13"
0748	Swivel Kingpin
12522	Stanchion Closed
12675	Trolling Motor Plug
12676	Trolling Motor Receptacle
0129	Screw for Receptacle (need 2)
0210	Mooring Cleat
3914	Rivet for Mooring Cleat (need 2)
1425	Aerator Hose
12590	Clip for Hose
12021	Rivet for Clip (need 2)
12563	Spray Head for Aerator
0042	Pump for Aerator
12021	Rivet for Aerator (need 2)

PARTS LIST

***Please have serial number available when ordering**

PRO 102 Requires 50 amp fuse.

12676	Trolling Motor Receptacle Female receptacle on boat (bow and stern)
12675	Trolling Motor Plug Male receptacle on motor
0241	Padded Seat
3889	Screw, 3/4" (4 per seat)
0748	Seat Mount Base- Kingpin Swivel
0124	Screw, #14 X 3 POH-SS (4 per boat)
0124	Screw, #14 X 2 POH-SS (8 per boat)
0743	Pedestal Seat Base (on boat)
2046	Battery Box
0361	Battery Strap
0263	Rubrail 22FT Black
12006	Rivets for Rubrail (need 8)
12036	Rivet Burrs for Rivets (need 8)
3845	Hatch Cover
0219	Hinge, Hatch Cover (need 2)
3913	Rivets for Hinge
0616	Thru Hull Fitting for Livewell
4254	Gasket for Livewell Fitting (requires 2)
0615	Thru Hull Fitting
4254	Gasket for Fitting (requires 2)
0167	Drain Plugs for Fittings
0046	Light Pole Stern
4078	Light Pole Bow
3609	Light Socket (boat contains 2)
2595	Pump Assembly

PRO 94

12676	Trolling Motor Receptacle Female receptacle on boat (bow and stern)
12675	Trolling Motor Plug Male receptacle on motor
0241	Padded Seat
3889	Screw, 3/4" (4 per seat)
0748	Seat Mount Base- Kingpin Swivel
0124	Screw, #14 X 3 POH-SS (4 per boat)
0124	Screw, #14 X 2 POH-SS (8 per boat)
0743	Pedestal Seat Base (on boat)
0361	Battery Strap
0263	Rubrail 22FT Black
12006	Rivets for Rubrail (need 8)
12036	Rivet Burrs for Rivets (need 8)
3845	Hatch Cover
0219	Hinge, Hatch Cover (need 2)
3913	Rivets for Hinge
0616	Thru Hull Fitting for Livewell
4254	Gasket for Livewell Fitting (requires 2)
0615	Thru Hull Fitting
4254	Gasket for Fitting (requires 2)
0167	Drain Plugs for Fittings
0017	In-line Fuse Assembly

WARRANTY

Please call us at 231-733-2725 if you have questions or a problem with your boat. Do not return the boat to the retailer.

KL Industries, Inc. warrants to the original owner of any KL Industries boat. Any part of the boat that is defective in material or workmanship will be repaired, without charge, at the purchasers' local dealer or at KL Industries.

For personal use, this warranty shall apply for a period of two years on the deck and hull and two years on parts from the date of retail sale. Any warranties from suppliers of component parts supersede KL Industries' warranty. This warranty covers use under normal conditions and does not cover damage caused by accidents, alteration, or misuse.

Freight to and from a local dealer or manufacturing plant is at the owners' expense.

Warranty is not valid unless registration form is returned within 30 days of retail purchase.

Register online at: www.klindustries.com

Warranty

OPTIONAL ACCESSORIES

Item Description	Model
<p>Mooring Cover Cover gives years of protection shielding out rain and debris. The elastic cord gives a snug, tight fit. Made of durable water resistant polyester fabric. Cover is supported by seats with backs folded down and by an adjustable center support pole (Pro 120 only) to eliminate puddling. Available in gray.</p>	<p>Pro 120 - #11238 Pro 102 - #ABT102CVGY Pro 94 - #ABT94CVGY</p>
<p>Deck Motor Mount For use with Pro 120 only. Carpeted block mount for mounting bow-style foot controlled trolling motors. Provides a 25 1/4" x 5 3/4" mounting area. Available in green.</p>	<p>Pro 120 - #11239</p>
<p>Set of Oars Set of 6' oars allows the boat to be rowed from the rear. Set includes two oars and oarlocks.</p>	<p>All models - #12738</p>
<p>Oarlock Socket Kit Attaches to boat. Set of 2.</p>	<p>Pro 102 & Pro 94 - #4124</p>
<p>Oarlock Set Includes two horns and two pins. Fits 1 3/8".</p>	<p>All models - #12586</p>



Mooring Cover

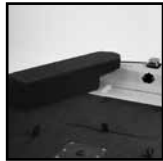

Deck Motor Mount



Set of Oars



Oarlock Set



Oarlock Socket Kit